

# EXPERT LVF - Linear Versatile Filler

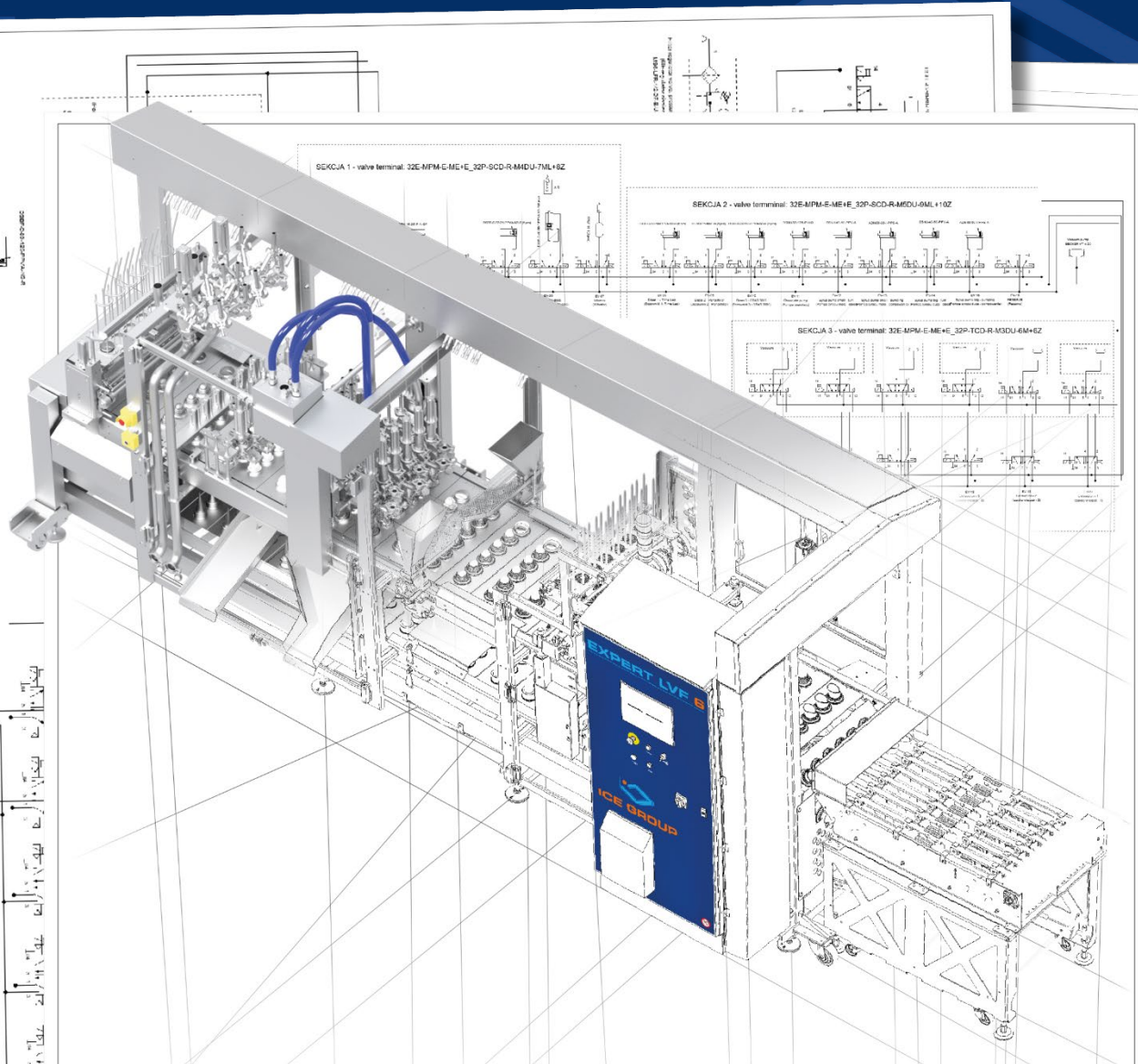

ICE GROUP



- universal, automatic, linear filling machine
- from 1-wide to 12-wide
- very wide range of dozed containers and dosing possibilities
- the highest possible level of customization and adjustment to your needs and also to specific, often atypical containers and unique dosing modes
- made with the use of best quality components of reputed suppliers with world-wide distribution chains, ensuring exploitation and production continuity safety, also in post-warranty period



REAL ALTERNATIVE TO EQUIPMENT OF TRADITIONAL MARKET LEADERS

# EXPERT LVF - Linear Versatile Filler

- all stainless steel / no aluminum technology related to all machine metal elements construction from bent stainless steel sheets for higher work hygiene
- hygienic construction obtained by avoiding closed profiles in the load-bearing constructions and replacing them with open profiles, C profiles or bent constructions.

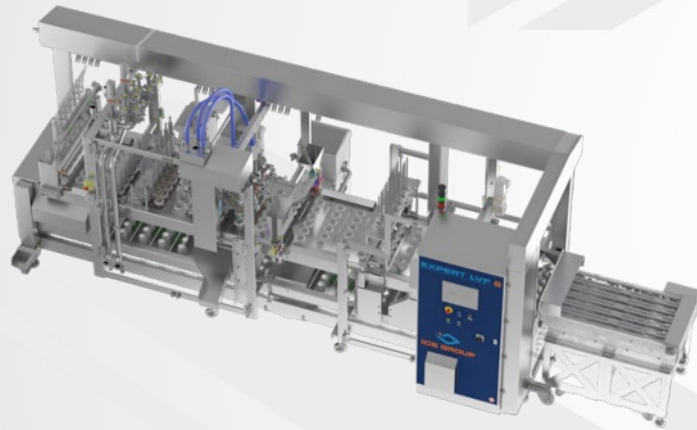
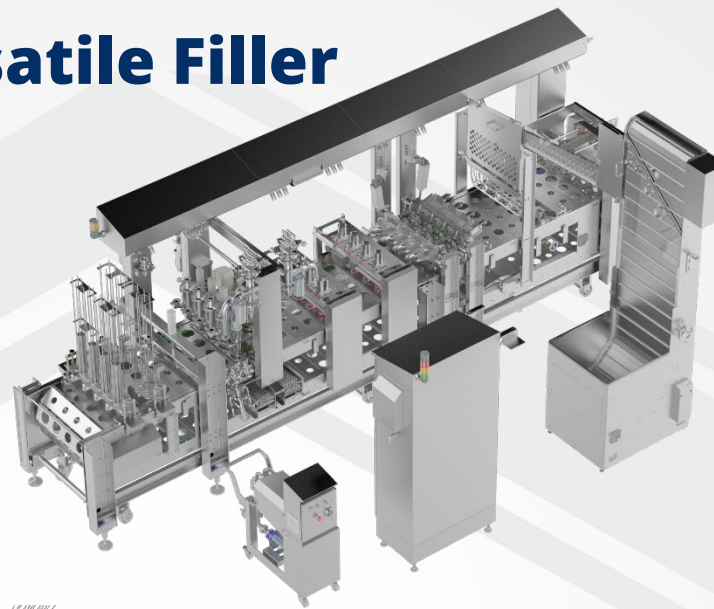

- CE standard safety shields

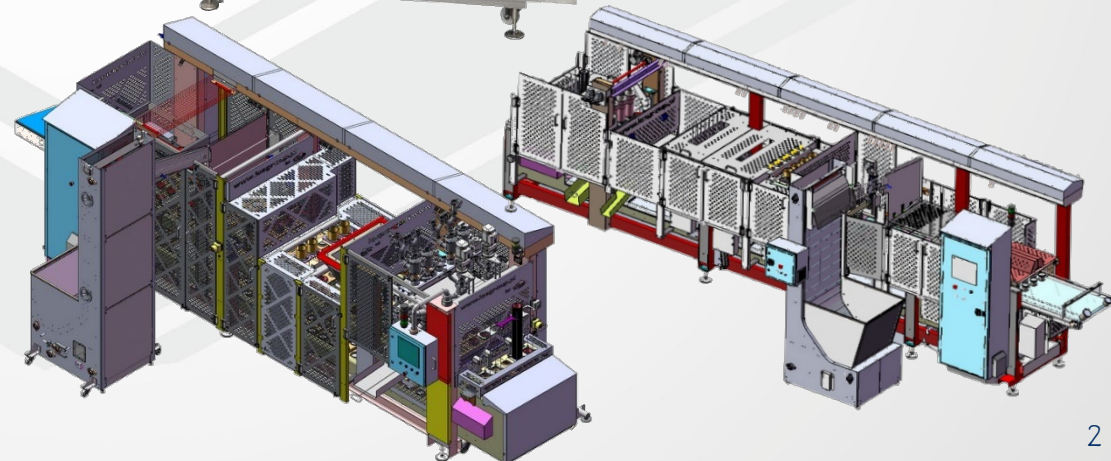



# EXPERT LVF - Linear Versatile Filler

## MAIN CONSTRUCTION FEATURES:

- servo motor drive for slatted conveyor
- servo-driven dosing column (one or more)
- many servo-driven dosing stations, possible to extend

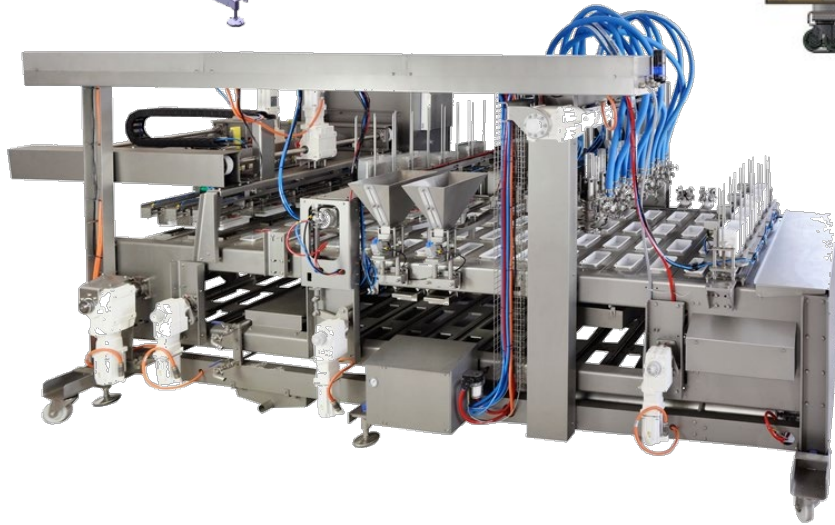
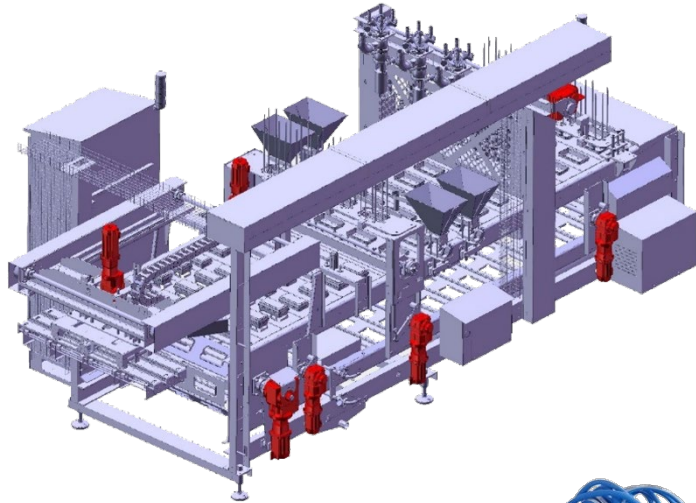
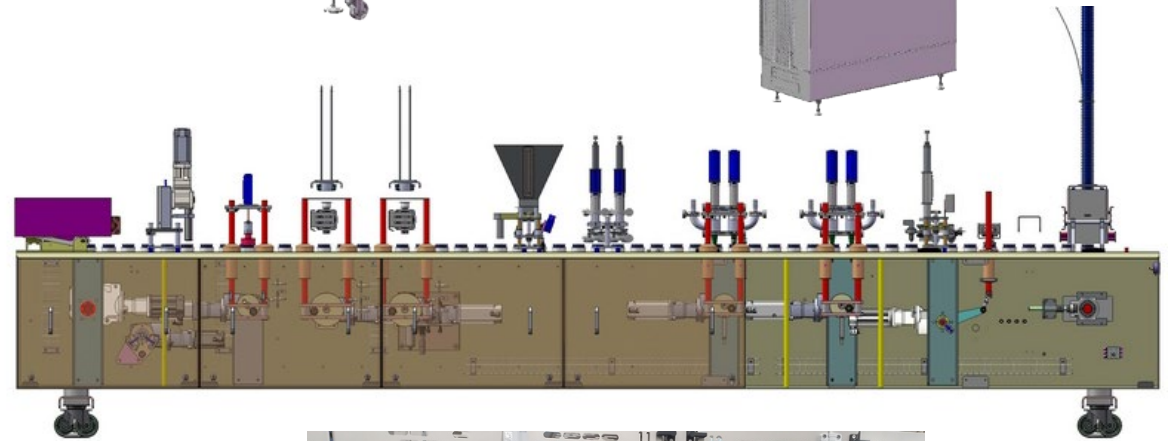
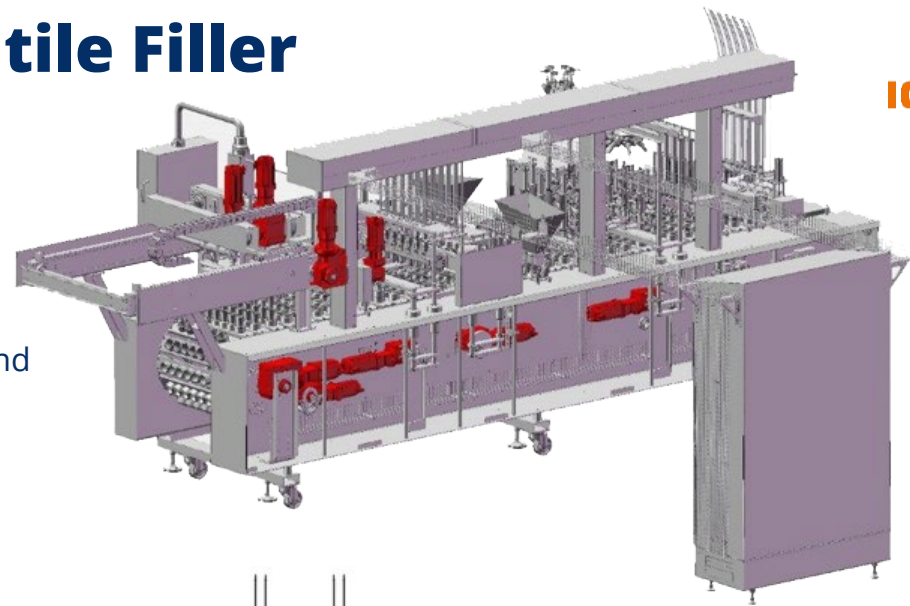

# EXPERT LVF - Linear Versatile Filler

## CONTROL AND STEERING:

- ➔ stainless steel electric cabinet for all electrical and electronic components including machine control system, equipped with air circulation system with air filters for overheating protection
- ➔ Allen Bradley or Siemens PLC controller with make-easy to operate and highly functional touchscreen control panel



- ➔ built-in Internet modem for remote diagnosis, service and monitoring as a part of „teleservice“

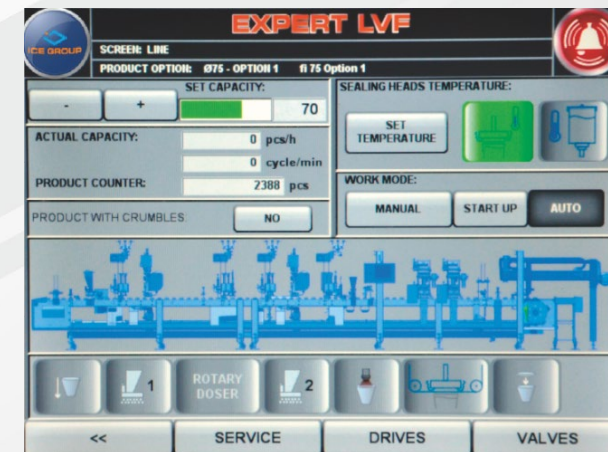



# EXPERT LVF - Linear Versatile Filler

## EXPERT LVF MODELS:

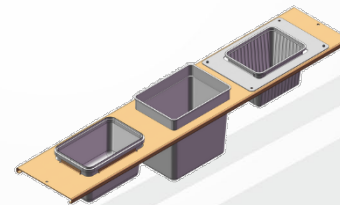
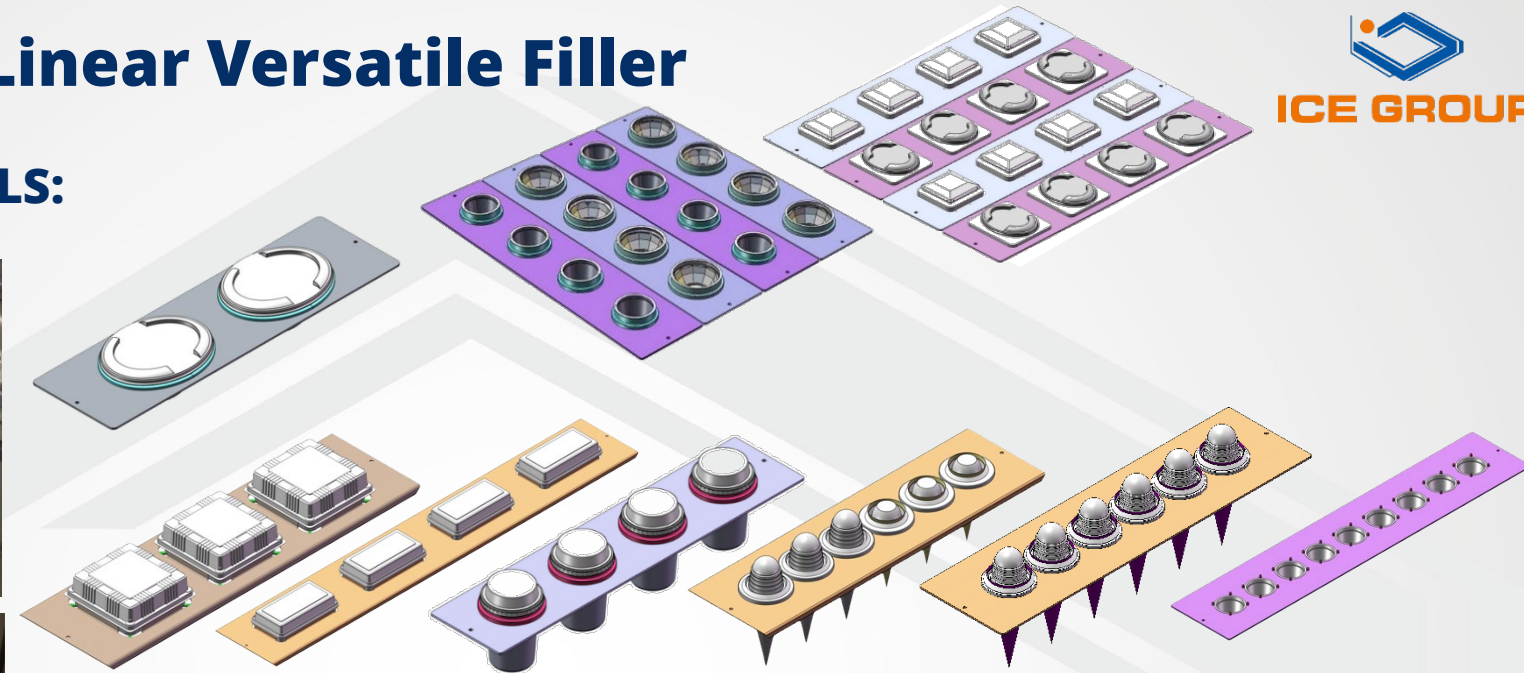

Standard model*	products	max. capacity
Expert LVF 1	1-5 liters tubs	1.200 pcs/h
Expert LVF 2	cups, cones, 1-5 liters tubs	4.400 pcs/h
Expert LVF 2+2	cups, cones, 1-2 liters tubs	8.800 pcs/h
Expert LVF 3	1-2 liters tubs	6.600 pcs/h
Expert LVF 3+3	cups, cones	13.200 pcs/h
Expert LVF 4	cups, cones	8.800 pcs/h
Expert LVF 6	cups, cones	13.200 pcs/h
Expert LVF 8	cups, cones	17.600 pcs/h
Expert LVF 9	cups, cones	19.800 pcs/h
Expert LVF 12	cups, cones	26.400 pcs/h
Expert LVF 4 DP	cups, cones	8.800 pcs/h
* Other models on request		



# EXPERT LVF - Linear Versatile Filler

## WIDE RANGE OF ADDITIONAL ACCESSORIES:

→ chocolate sprays

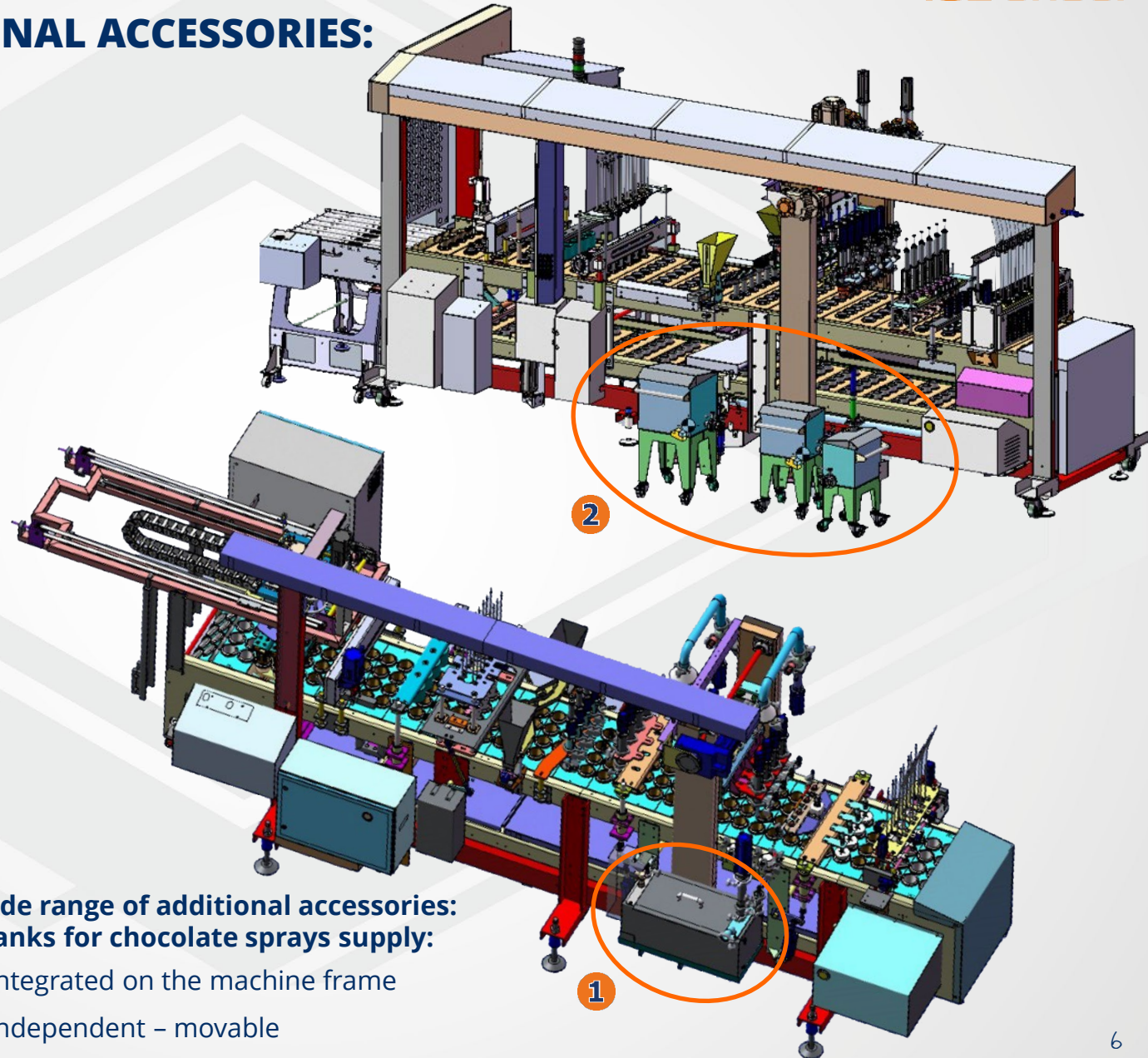
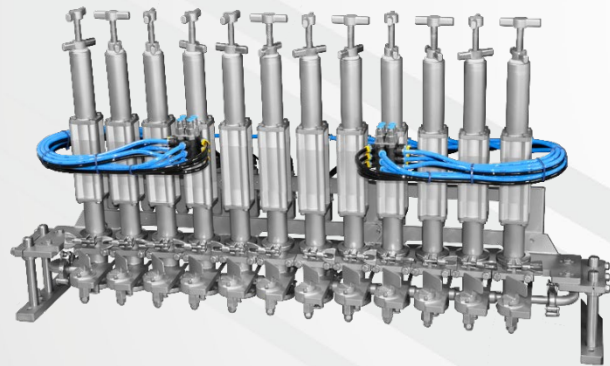

Wide range of additional accessories:  
- tanks for chocolate sprays supply:

- ① Integrated on the machine frame
- ② Independent - movable



# EXPERT LVF - Linear Versatile Filler

## WIDE RANGE OF ADDITIONAL ACCESSORIES:

→ Ice cream dozers

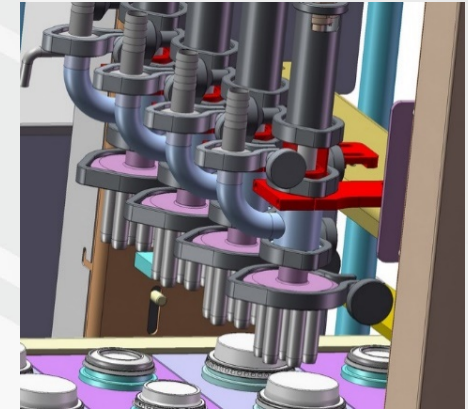
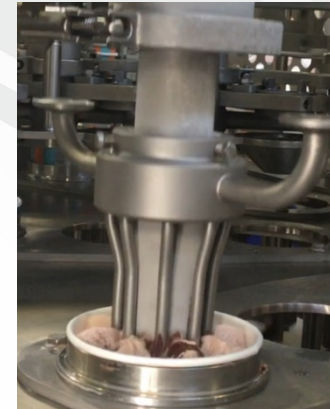
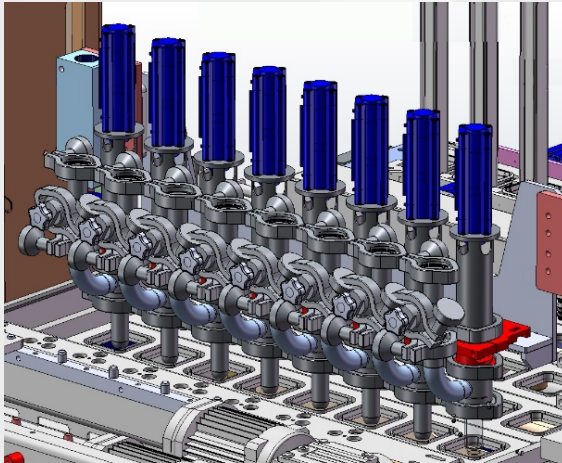

# EXPERT LVF - Linear Versatile Filler

ALL ICE GROUP FILLERS CAN BE APPLIED:

➔ NON-SWIRL FILLERS 1, 2, 3-colour also with sauce stripes and pencils

Time lap

Star 1000

„Tartuffo”

Radial partitioning

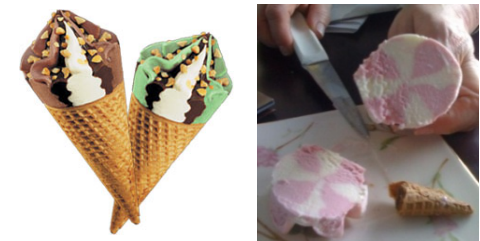

➔ Ask for special dosing nozzles working with extra large inclusions!





# EXPERT LVF - Linear Versatile Filler

ALL ICE GROUP FILLERS CAN BE APPLIED:

→ SWIRLING FILLERS

Star 3000

Cobra

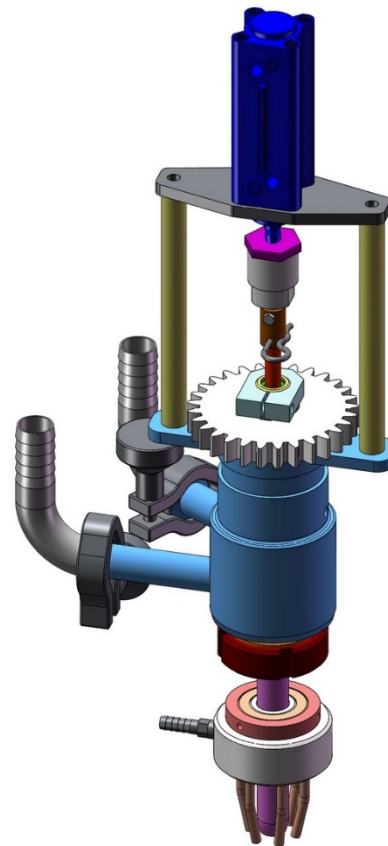
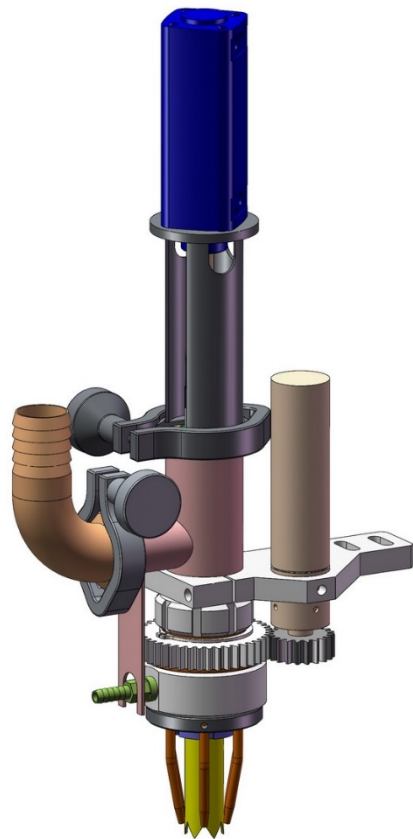

# EXPERT LVF - Linear Versatile Filler

ALL ICE GROUP FILLERS CAN BE APPLIED:

➔ MULTI-NOZZLE DOZERS AND DOZER COMBINATIONS

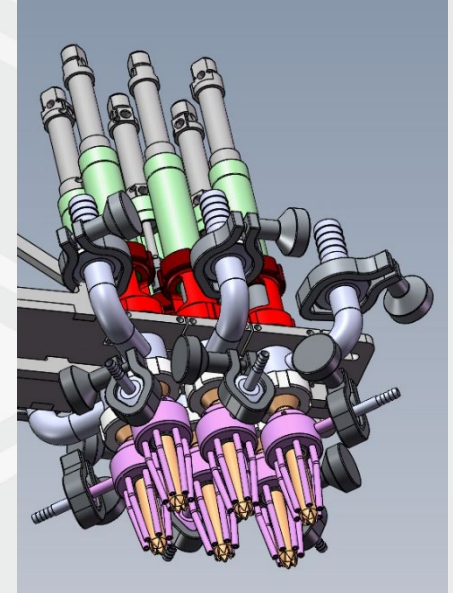
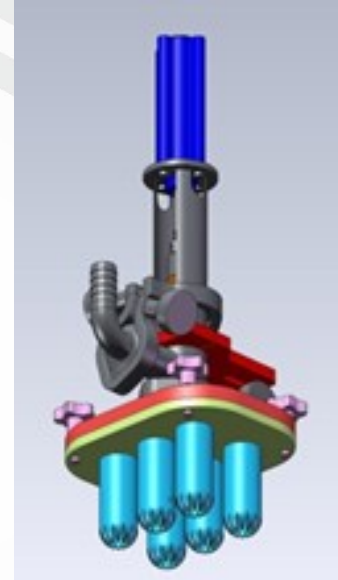
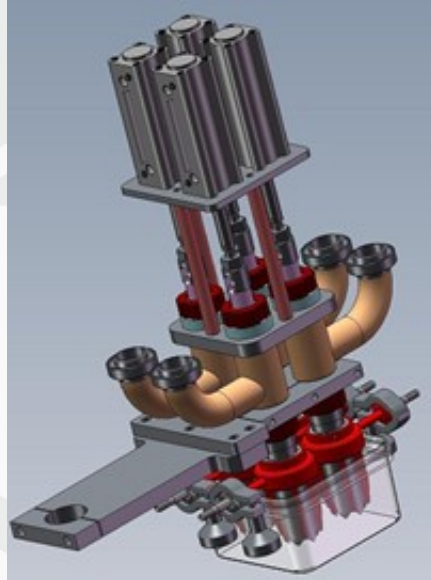



# EXPERT LVF - Linear Versatile Filler

## WIDE RANGE OF ADDITIONAL ACCESSORIES:

→ topping dozers

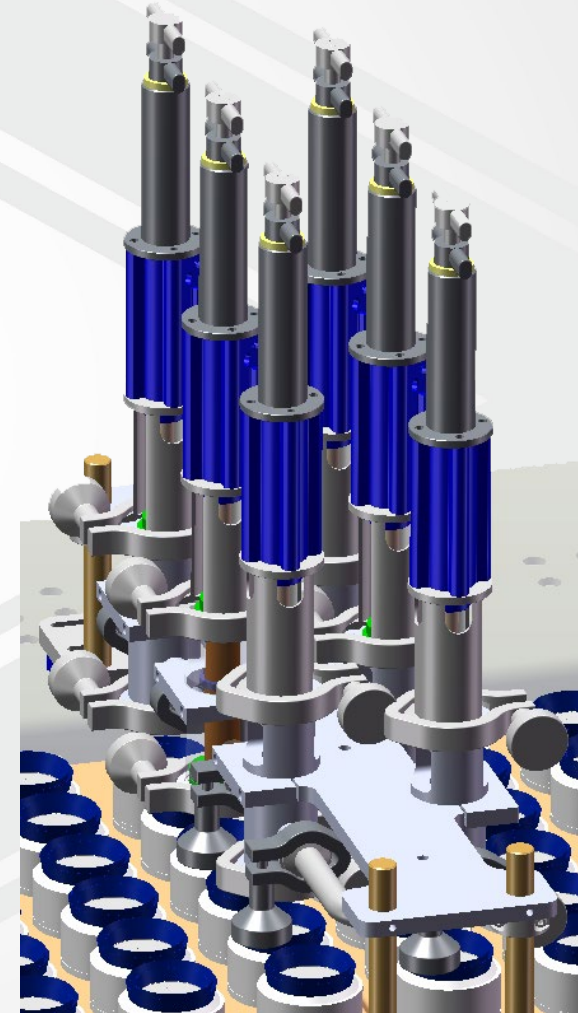
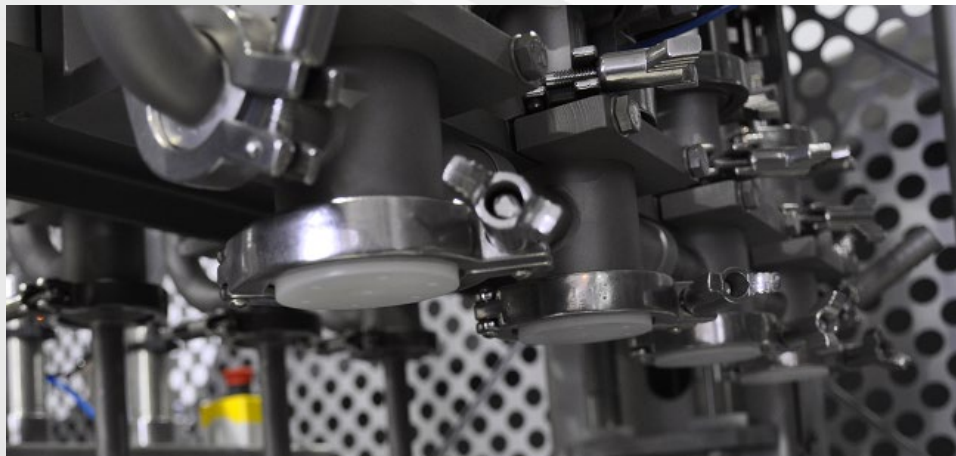

# EXPERT LVF - Linear Versatile Filler

## WIDE RANGE OF ADDITIONAL ACCESSORIES:

- 1 standard vibrators
- 2 Individually controlled vibrators
- 3 Extra big inclusions version

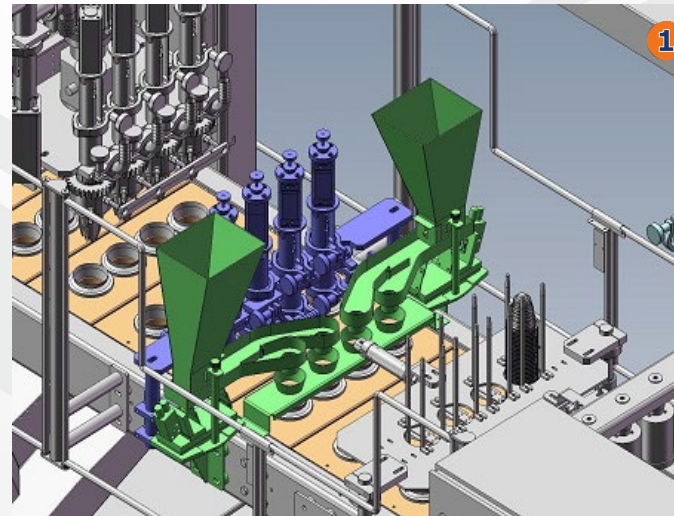
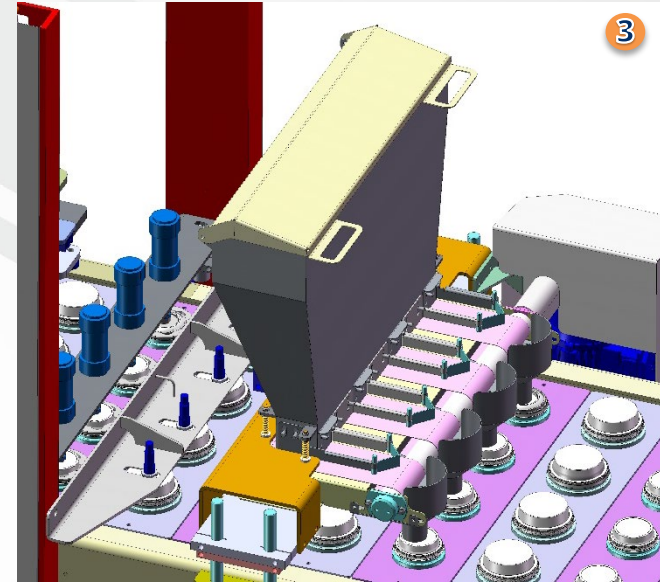
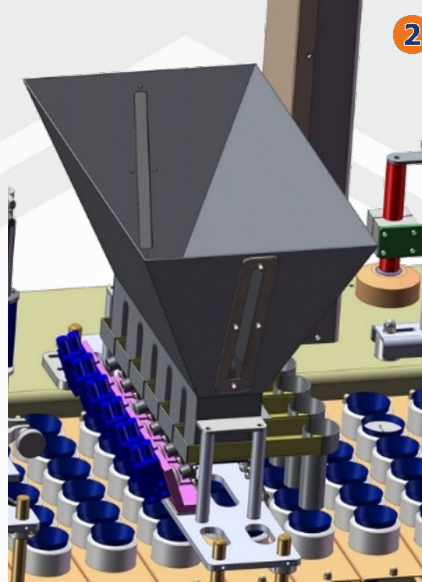



# EXPERT LVF - Linear Versatile Filler

## CLOSING SYSTEMS:

- cardboard lids
- snap-on lids
- pre-cut lids sealing ①
- sealing with film from a reel ②
- second lids closing
- cones crimping ③





# EXPERT LVF - Linear Versatile Filler

## HIGHER AUTOMATION LEVELS:

- unscrambler for non-stacking lids ①
- automatic cups stacks feeder ②

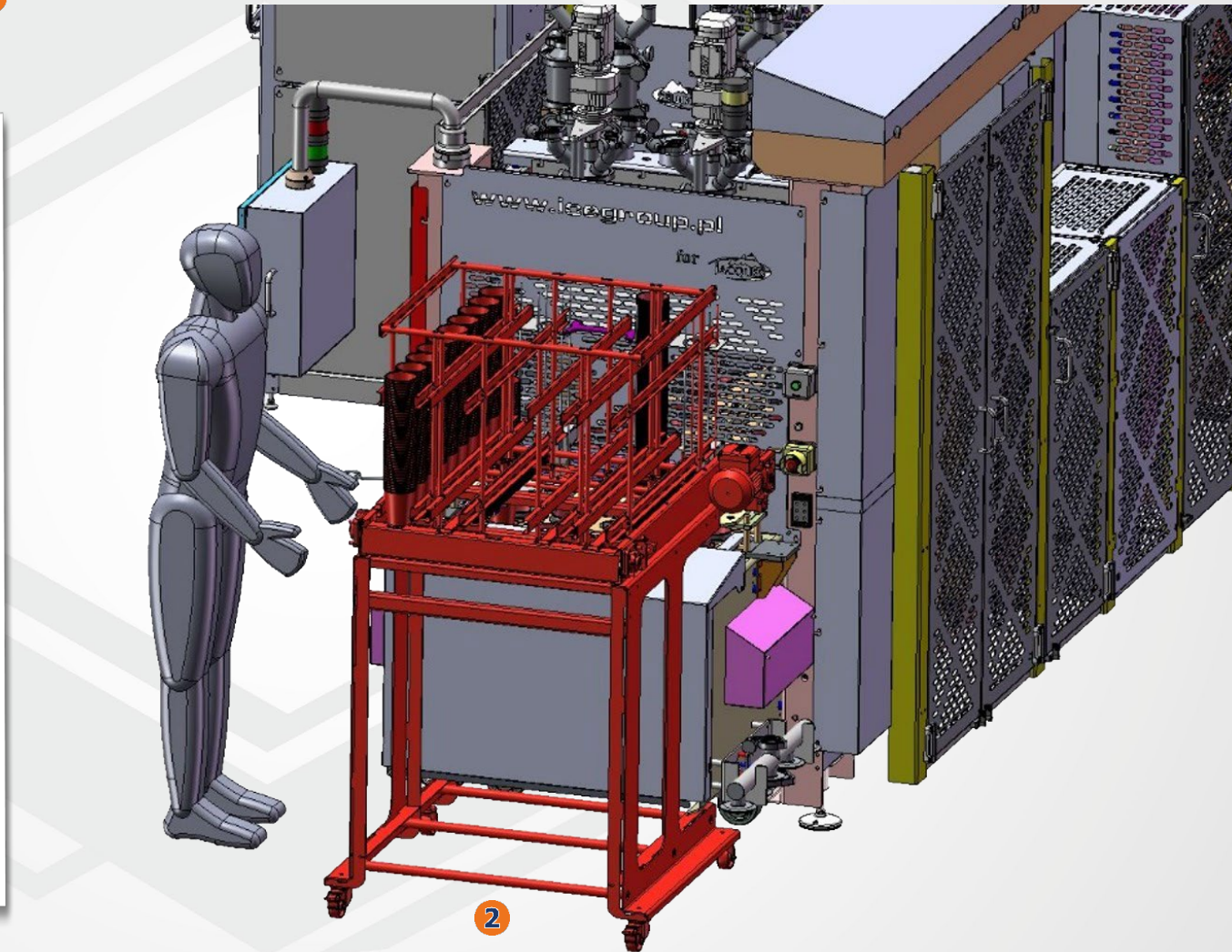



# EXPERT LVF - Linear Versatile Filler

## AUTOMATIC TRANSFER:

- ➔ Automatic transfer of cups, cones and squeeze-ups to hardening tunnels in vertical position

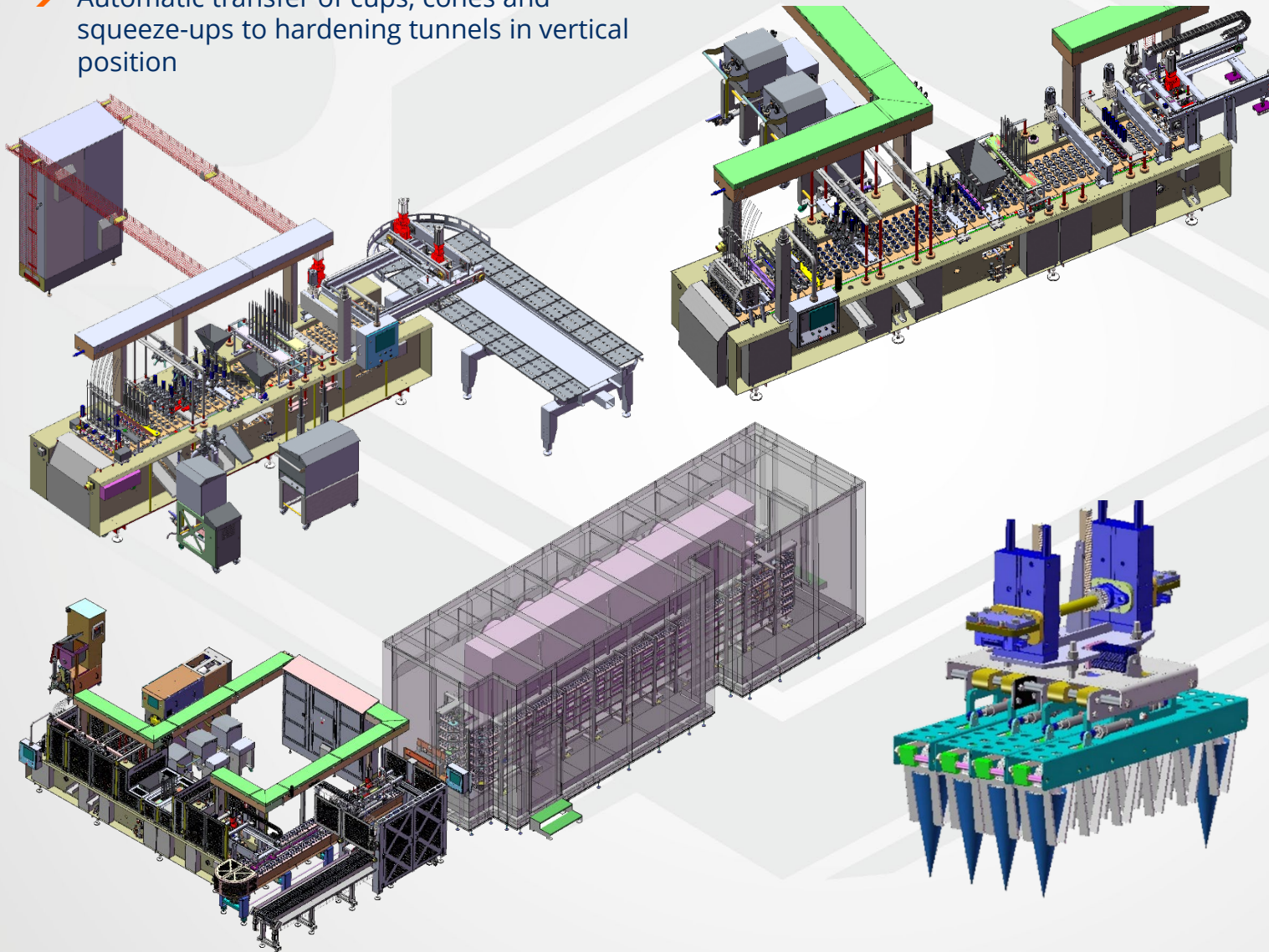

# EXPERT LVF - Linear Versatile Filler



ICE GROUP

## Auxiliary Accessories – Master IF ingredients feeders and pumps:



Master IF 3000  
fruit feeder with  
CCF (Constant  
Crispies Feeder)



Master IF 4000 Dual  
fruit feeder with  
divided tank



Three piston pumps for  
syrup with divided hopper



One piston pump for syrup or  
chocolate with heated hopper



Worm syrup pump



Two piston pumps for syrup  
with divided hopper



Cam pump for syrup



# COMMERCIAL DIVISION



**Reema Handall**

**Commercial Division Coordinator**



English- Arabic- and French-speaking markets  
Middle East, North Africa



**Ewa Bernacka**

**Commercial Division Administrator**



English- and German-speaking markets  
Europe, Asia, Africa



**Agnieszka Gańczorz**

**Market Development Manager**



English- and Spanish-speaking markets,  
Middle, South & North America, Europe, India



**Aleksander Zinkowski**

**Export specialist**



Russian-speaking markets  
Russia, Ukraine, Belarus, Kazakhstan

# BOARD OF DIRECTORS

**L. Arkadiusz Geratowski**

**President and Commercial Director**



**Mariusz Goik**

**General Manager and Vice President**

